

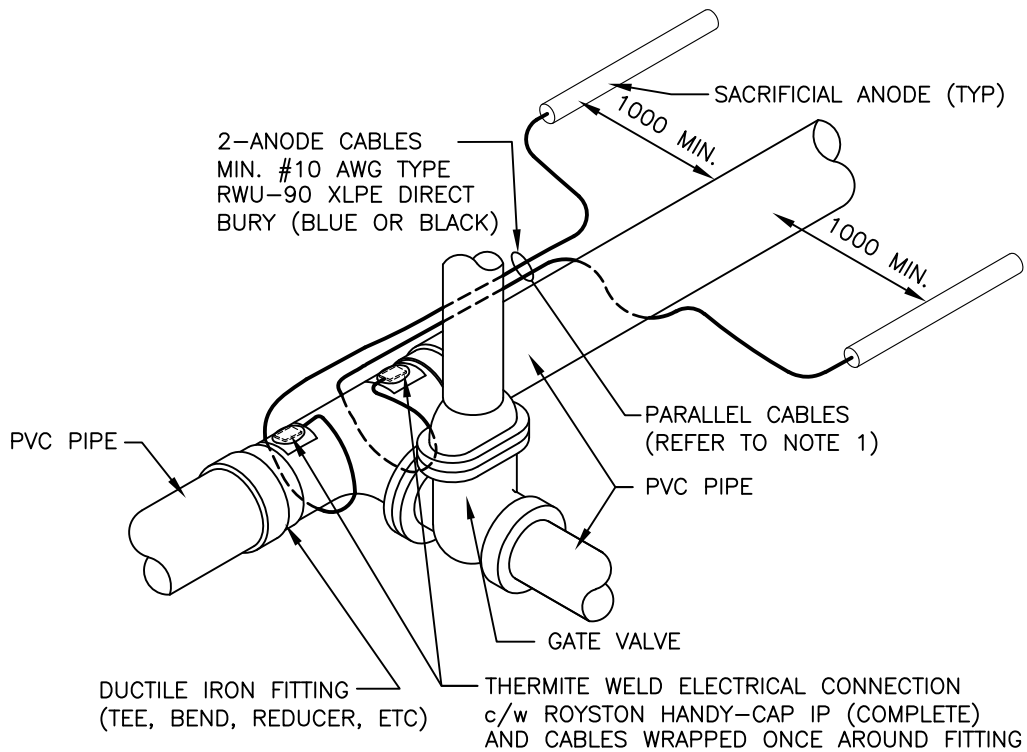

TYPICAL THERMITE WELD ELECTRICAL CONNECTION



TYPICAL TWO ANODE INSTALLATION

- NOTE:
1. ALL CABLES PARALLEL TO PIPE TO BE ATTACHED TO PIPE USING PIPE TAPE.
 2. PUNCTURE CARDBOARD TUBE AND SOAK ANODE IN WATER BEFORE BURY.

NOT TO SCALE

No.	DATE	REVISION DESCRIPTION	BY	APP
4	APR2022	REVIEWED AND UPDATED 2022	IP	JDh
3	MAY2019	REVIEWED AND UPDATED 2019	DAR	CM

TWO ANODE INSTALLATION



DWG. No. SW16
REV. 4