

DRIVEWAY CROSSING WITH BARRIER CURB AND GUTTER

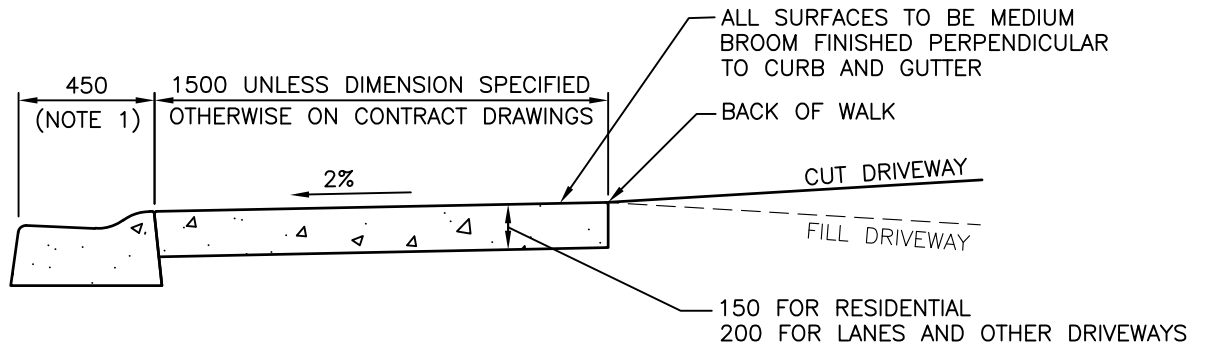

INFILL DRIVEWAY CROSSING AT ROLL-OVER CURB AND GUTTER

- NOTES:
1. REFER TO DRAWING C4 FOR CURB AND GUTTER DIMENSIONS.
 2. REFER TO CONTRACT DRAWINGS AND SECTION 03 30 20 FOR DETAILED SPECIFICATIONS.
 3. CONTINUE ROAD SUBBASE AND BASE UNDER CURB, GUTTER AND DRIVEWAY CROSSING.
 4. TRAVERSE CONTRACTION JOINTS SHALL BE AT 3000 c/c USING SURFACE GROOVING.
 5. EXPANSION JOINT AT BOTH ENDS OF CROSSING.
 6. DRIVEWAY CROSSING TO BE HAND FORMED AS MONOLITHIC WHEN MONOLITHIC CURB, GUTTER AND SIDEWALK.
 7. ALL CONTRACTION AND EXPANSION JOINTS SHALL BE STRAIGHT.
 8. DRIVEWAYS TO BE RECONSTRUCTED OF CONCRETE BETWEEN CURB AND SEPARATED SIDEWALKS.

NOT TO SCALE

DRIVEWAY CROSSING AT SIDEWALKS AND CURBS



No.	DATE	REVISION DESCRIPTION	BY	APP
7	APR2022	REVIEWED & UPDATED 2022	IP	JDh
6	FEB2019	REVIEWED & UPDATED 2019	DAR	JDh

DWG. No. **SC7**
REV. **7**